

This article was downloaded by:

On: 24 January 2011

Access details: *Access Details: Free Access*

Publisher *Taylor & Francis*

Informa Ltd Registered in England and Wales Registered Number: 1072954 Registered office: Mortimer House, 37-41 Mortimer Street, London W1T 3JH, UK



## Journal of Macromolecular Science, Part A

Publication details, including instructions for authors and subscription information:

<http://www.informaworld.com/smpp/title~content=t713597274>

### Synthesis of Beaded Polyvinyl Alcohol by Suspension Methanolysis of Polyvinyl Acetate: Derivatization and Some Applications

M. Dimonie<sup>a</sup>; H. D. Schell<sup>b</sup>; G. Hubc<sup>a</sup>; M. A. Mateescu<sup>b</sup>; C. G. Oprescu<sup>a</sup>; S. Todireanu<sup>c</sup>; O. Maior<sup>a</sup>; J. Languri<sup>a</sup>; M. Iosif<sup>a</sup>

<sup>a</sup> Department of Organic Chemistry and Technology, Polytechnic Institute of Bucharest, Bucharest, Romania <sup>b</sup> Institute of Biological Sciences, Bucharest, Romania <sup>c</sup> Institute for Physics and Technology of Materials (IFTM), Bucharest-Măgurele, Romania

**To cite this Article** Dimonie, M. , Schell, H. D. , Hubc, G. , Mateescu, M. A. , Oprescu, C. G. , Todireanu, S. , Maior, O. , Languri, J. and Iosif, M.(1985) 'Synthesis of Beaded Polyvinyl Alcohol by Suspension Methanolysis of Polyvinyl Acetate: Derivatization and Some Applications', *Journal of Macromolecular Science, Part A*, 22: 5, 729 — 754

**To link to this Article:** DOI: 10.1080/00222338508056633

**URL:** <http://dx.doi.org/10.1080/00222338508056633>

PLEASE SCROLL DOWN FOR ARTICLE

Full terms and conditions of use: <http://www.informaworld.com/terms-and-conditions-of-access.pdf>

This article may be used for research, teaching and private study purposes. Any substantial or systematic reproduction, re-distribution, re-selling, loan or sub-licensing, systematic supply or distribution in any form to anyone is expressly forbidden.

The publisher does not give any warranty express or implied or make any representation that the contents will be complete or accurate or up to date. The accuracy of any instructions, formulae and drug doses should be independently verified with primary sources. The publisher shall not be liable for any loss, actions, claims, proceedings, demand or costs or damages whatsoever or howsoever caused arising directly or indirectly in connection with or arising out of the use of this material.

**Synthesis of Beaded Polyvinyl Alcohol by  
Suspension Methanolysis of Polyvinyl Acetate:  
Derivatization and Some Applications**

**M. DIMONIE**

Department of Organic Chemistry and Technology  
Polytechnic Institute of Bucharest  
Bucharest 71102, Romania

**H. D. SCHELL**

Institute of Biological Sciences  
Bucharest 77748, Romania

**G. HUBCĂ**

Department of Organic Chemistry and Technology  
Polytechnic Institute of Bucharest  
Bucharest 71102, Romania

**M. A. MATEESCU**

Institute of Biological Sciences  
Bucharest 77748, Romania

**C. G. OPRESCU**

Department of Organic Chemistry and Technology  
Polytechnic Institute of Bucharest  
Bucharest 71102, Romania

**S. TODIREANU**

Institute for Physics and Technology of Materials (IFTM)  
Bucharest-Măgurele, Romania

**O. MAIOR, J. LANGURI, and MARIANA IOSIF**

Department of Organic Chemistry and Technology  
Polytechnic Institute of Bucharest  
Bucharest 71102, Romania

## ABSTRACT

A new procedure for the synthesis of porous and nonporous polyvinyl alcohol beads by controlled methanolysis of different concentrations of polyvinyl acetate suspension is described. By crosslinking with epichlorohydrin, insoluble crosslinked polyvinyl alcohol gels were obtained. These gels exhibit some peculiar swelling properties related to the reticulation degree, probably due to the interchain hydrogen associations. Crosslinked polyvinyl alcohol beads can be used as supports for liquid chromatography and for enzyme immobilization. Some new stationary phases for affinity chromatography and for ion-exchange chromatography were obtained. No substantial modifications in the catalytic properties of enzyme immobilized on crosslinked polyvinyl alcohol gels were established.

## INTRODUCTION\*

The great interest recently paid [1, 2] to PVA is fully justified by its major implications in a series of industrial processes and, on the other hand, by its utilization as a packing material for chromatography and as a material with several present and future possibilities of biomedical applications.

PVA is mainly obtained by methanolysis of PVAc under conditions of basic catalysis. It is well known that the alcoholysis of PVAc exhibits some peculiarities. A strong self-acceleration effect induces high reaction velocities [3]. This effect is explained by a "zipper-type" reaction mechanism (Fig. 1). The catalyst molecule determining the hydrolysis of an acetate group is retained by the "new born" generated HO- group by hydrogen bonds. There is a high probability that the hydrolysis of the vicinal acetate group is catalyzed by this one molecule of catalyst adsorbed (or chemisorbed) on the chain, and not by other catalyst molecules that are more distance from the solution.

As a consequence, the hydrolysis reaction is developed along the chain, generating the block copolymer structure of the partially hydrolyzed product. The time course of block formation implies several steps. At the beginning the process takes place in homogeneous solution, where the macromolecules are relaxed. Once the HO- groups are

---

\*Abbreviations: PVA = polyvinyl alcohol; PVAc = polyvinyl acetate; CL-PVA = crosslinked PVA; CL-PVA-X-5, Cl-PVA-X-10, etc. = different types of Cl-PVA (X indicates that the PVA is crosslinked, and the number indicates the amount, in terms of grams of epichlorohydrin, used to crosslink 100 g of PVA).

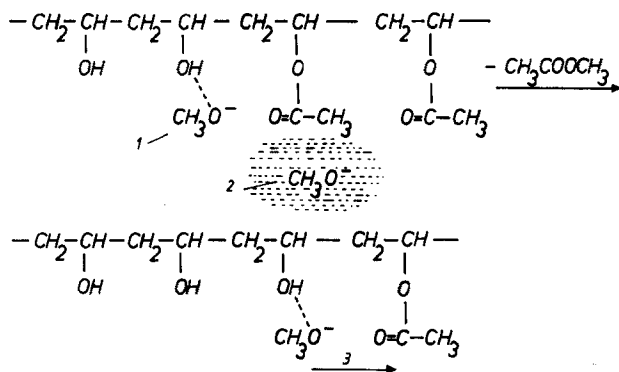


FIG. 1. Zipper-type mechanism of hydrolysis reaction development. 1) Catalyst molecule bound to OH group by hydrogen bonds. 2) Catalyst molecule in solution. 3) Direction of hydrolysis reaction progress.

released, they are involved in hydrogen associations; the number of these hydrogen bonds increases as a direct function of the degree of hydrolysis. Due to these hydrogen bonds, the viscosity of the reaction mixture increases to a maximum limit of 65% degree of hydrolysis at which point the whole mass turns into a very consistent gel (generating, under certain conditions, blockage of the reactors). This gel depends on the concentration of the starting PVAc solution (Fig. 2) [4].

The shear effort obtained in a Brabander-type grinder is also a function of polymer concentration. Acceptable efforts are limited to concentrations up to 25% PVAc.

Both the high reaction rate and gel formation determine some technological shortcomings related to the degree of hydrolysis and the equipment.

The reaction cannot be controlled by preliminary analysis. Alcoholysis should be conducted in high power units (such as screw mixers, hydromotor driven, special agitator reactors) that are able to break the gel. On the other hand, the concentration of PVAc lacquer subjected to hydrolysis cannot be higher than 20% (Fig. 2).

These disadvantages were eliminated by Dimonie and co-workers, whose technology [5] permitted the production of beaded, porous PVA in traditional reactors with normal stirring.

#### SYNTHESIS OF BEADED PVA BY SUSPENSION METHANOLYSIS OF PVAc

The procedure consists of dispersing the PVAc solution in an immiscible medium such as paraffin oil [5]. In these conditions, hydroly-

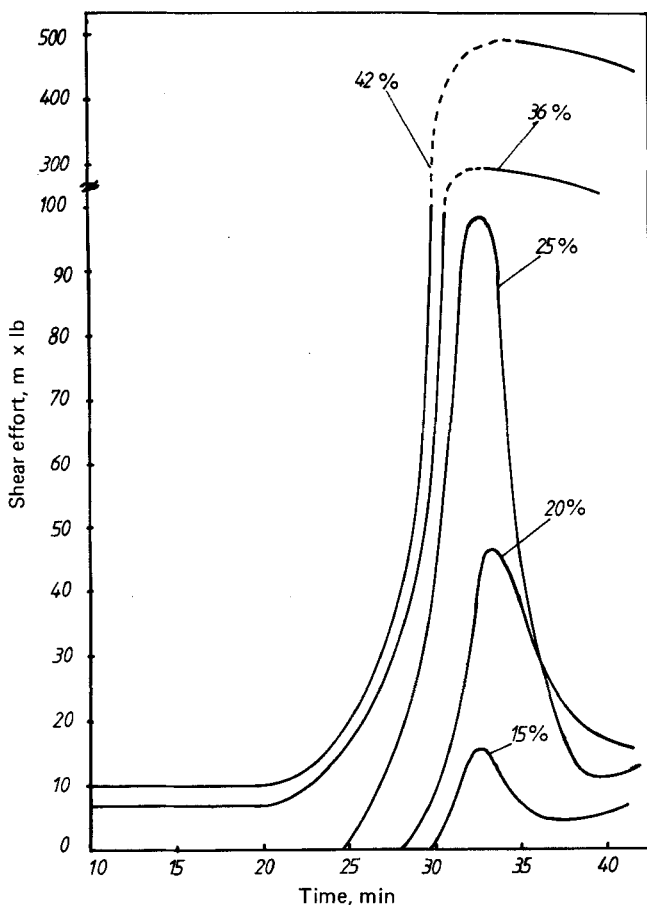


FIG. 2. Dependence of the maximum shear effort of the polyvinyl acetate concentration and time in the homogeneous stage. The PVA concentrations are given on the curves.

sis occurs at the level of beads formed by lacquer stirred dispersion, while the formation of compact gel and reactor blocking phenomena are fully eliminated. The method provides possibilities for control of the degree of hydrolysis by the rapid determination of methyl acetate in the reaction medium. The other main advantage of this process is the decrease by three to five times of the power consumption due to the avoidance of gel formation. Another advantage is that the procedure yields the desired bead size.

Kinetic behavior, influence of temperature, catalyst concentration, and PVAc concentration in this biphasic system are similar to those

TABLE 1. Dependence of the Stability of PVAc Suspension in Paraffin Oil on the Solution Concentration and the Oil/PVAc Solution Volumetric Ratio

Concentration of PVAc solution, % by weight	Oil/PVAc solution volumetric ratio	Suspension stability
20	1:1	Stable
40	1:1	Unstable
	1.5:1	Stable
	2:1	Stable
50	1:1	Unstable
	1.5:1	Unstable
	2:1	Stable

of the homogenous system, and they are in good agreement with the literature data [3], except for the block structure.

The reaction can be developed at higher PVAc concentrations only when the paraffin oil/PVAc ratio is increased to provide suspension stability (Table 1). This ratio is of primary importance for the development of the reaction.

By performing the hydrolysis reaction using a 40% PVAc solution concentration, a decrease of 50% in methanol consumption is possible. A concentration of 20% for the PVAc solution is necessary for hydrolysis in a homogeneous solution.

PVA porous beads retain large amounts of oil that cannot be released by simple washing. This unexpected behavior, which takes into account the fact that the two phases are not miscible, requires a special technological step: oil extraction from the porous beads. For this reason, two lines of research were developed. One focused on finding the factors determining oil retention and the second on obtaining beads that are not able to retain oil. For this purpose, PVA beads were prepared by hydrolysis of various concentrations of PVAc solution. To accomplish this, another method for PVAc methanolysis was developed [6]. Scanning electron microscopy studies with the PVA beads showed some interesting aspects. The beads prepared by methanolysis of 20 and 30% PVAc solutions exhibit numerous pores (Fig. 3) in which paraffin oil is retained. The pores are probably formed as follows. During hydrolysis, new intramolecular hydrogen associations are established between the "new born" HO- released groups. These associations result in shrinkage of the macromolecule. This causes the solvent (methanol and methyl acetate) to be expelled, thus generating pores.

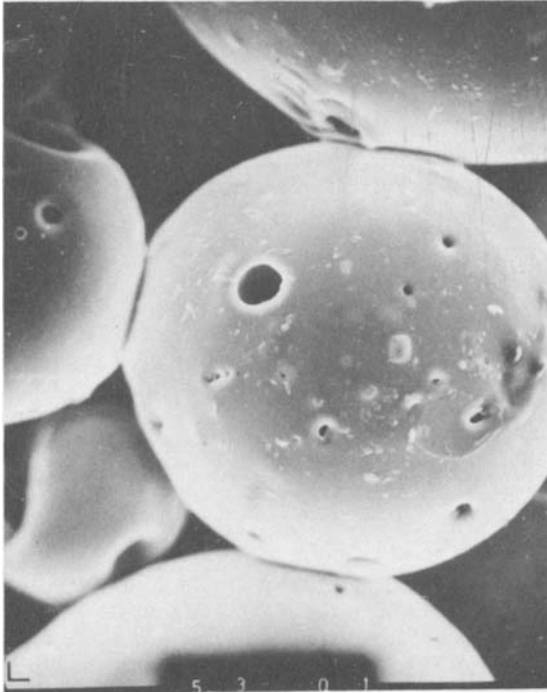


FIG. 3. Porous beads obtained by hydrolysis of 20% polyvinyl acetate solution (450 $\times$ ).

In the case of high concentrations of PVAc, the retention of oil is hindered. Consequently the beads exhibit smooth surfaces (with a real chance to be used in cell biology)\* (Fig. 4).

Oil extraction was performed using a gasoline, cyclohexane, benzene, and methanol-methyl acetate azeotropic mixture. Extraction kinetics indicate that the amount of oil retained depends on the beads structure (Fig. 5). The highest extractions values were established for beads with a large porosity obtained from 20 and 30% PVAc starting solutions. In the case of PVA beads with reduced porosity (obtained from 40 and 50% PVAc), the amount of oil retained was much smaller and a simple washing was sufficient to eliminate the oil.

This newly described procedure also permits control of the degree of hydrolysis, the bead size, and the porosity. On the other hand, by

---

\*Solid phase techniques in cell biology require beads with smooth surfaces. The "undesired" and nonspecific retention of cells within these pores is to be avoided.

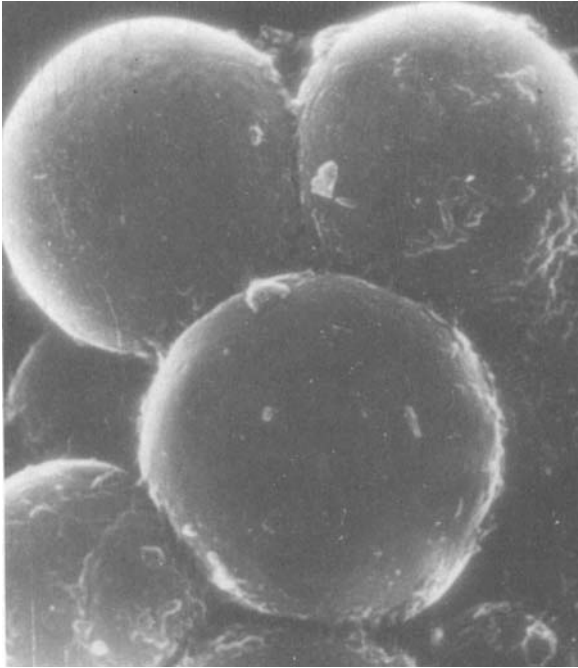


FIG. 4. Nonporous beads obtained by hydrolysis of 50% polyvinyl acetate solution (450 $\times$ ).

using concentrated PVAc solutions, oil extraction is avoided. This is an important technological advantage due to the low consumption of materials, power, and time.

Based on the described methods for porous and nonporous PVA bead preparation, many applications using various types of beads were developed. Thus, besides their main industrial utilization for fibers, films, and surfactants, the nonporous beads, after reticulation by epichlorohydrin, were used in some immunological procedures. Cross-linked porous PVA beads were used for the synthesis of some new stationary phases for ion-exchange and affinity chromatography.

#### CROSSLINKING AND DERIVATIZATION OF PVA BEADS

The procedure for CL-PVA (Fig. 6) synthesis was previously described [7, 8].



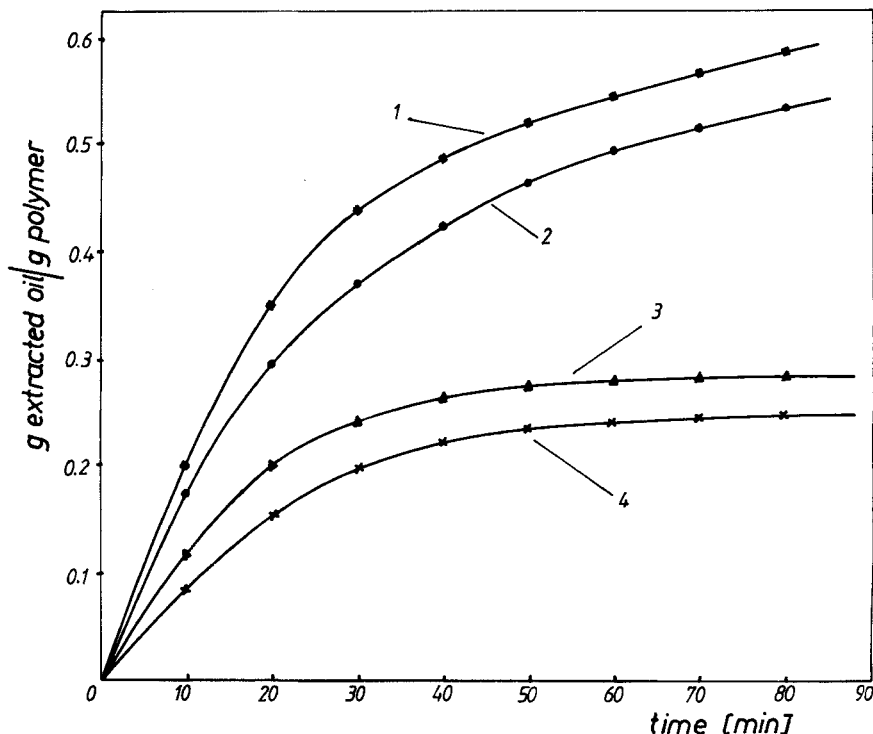


FIG. 5. Dependence of the amount of oil absorbed and of the extraction kinetics on the polyvinyl acetate solution during hydrolysis. NaOH = 0.4%; temperature = 30°C. 1) PVAc = 20%; 2) 30%; 3) 40%; 4) 50%.

According to the PVA/epichlorohydrin ratio, different preparations with various degrees of reticulation (CL-PVA-X-5, CL-PVA-X-10, CL-PVA-X-20, CL-PVA-X-30, and CL-PVA-X-40) were obtained [7].

The reticulation was performed at such a temperature that the bead form of PVA was preserved (Fig. 7), even after the 5 and 10 M sodium hydroxide treatment used for synthesis.

Some swelling properties of CL-PVA gels related to the degree of reticulation were established (Table 2) [9, 10].

It is well known that polyhydroxyl chromatographic stationary phases based on CL-dextrans (Sephadex gels) CL-agarose, and CL-amyllose, with high degrees of reticulation, generate reduced capacities to swell due to the high number of interchain glycerine bridges that do not permit the swelling of gels, even if the HO- groups are hydrated [11-13].

Unlike the above compounds, CL-PVA gels exhibit an increase of all



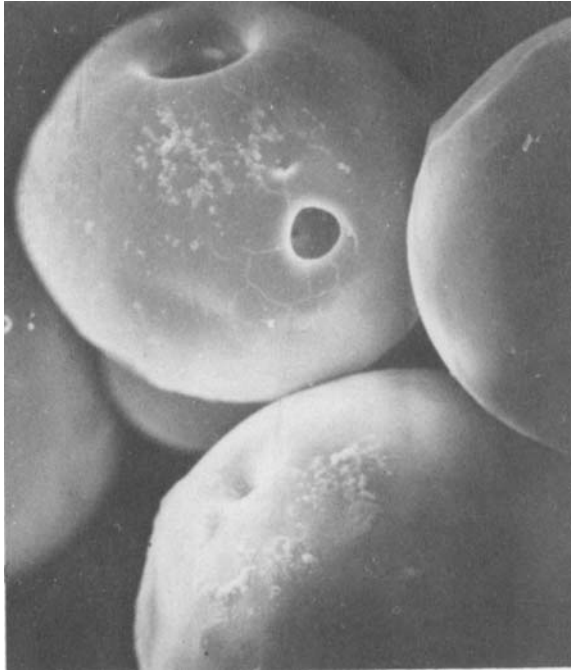


FIG. 7. Scanning electron microscopy of PVA beads after cross-linking and derivatization, CM-PVA-CL; 450 $\times$ .

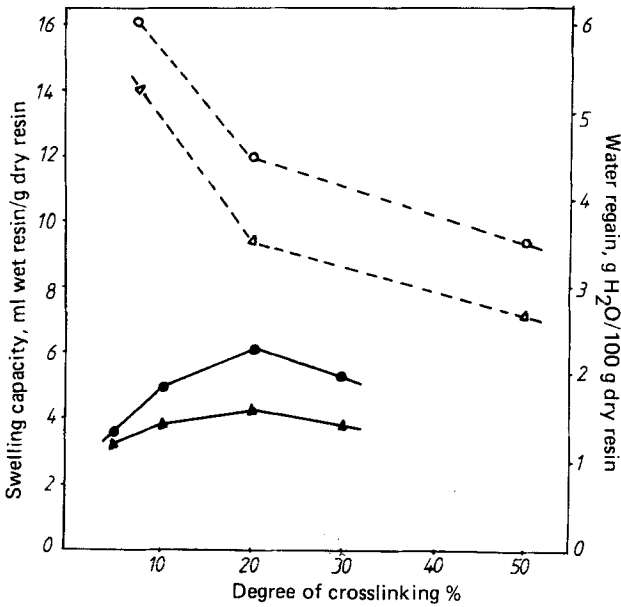


FIG. 8. Dependence of swelling capacity of CL-PVA ( $\blacktriangle$ ) and CL-amylose ( $\triangle$ ) and of water regain of CL-PVA ( $\bullet$ ) and CL-amylose ( $\circ$ ) on the crosslinking degrees.

TABLE 2. Swelling Properties of CL-PVA Gels with Different Degrees of Reticulation

Type of gel	Bed volume, mL gel/g	Water regain, g H <sub>2</sub> O/g	Humidity, g H <sub>2</sub> O/100 g	Observations
CL-PVA-X-5	3.33	1.39	5.31%	Abnormal behavior (different from other hydroxilic gels)
CL-PVA-X-10	3.90	1.86	5.48%	
CL-PVA-X-20	4.45	2.28	5.66%	
CL-PVA-X-30	3.90	1.90	3.98%	Normal behavior (like other hydroxilic gels)
CL-PVA-X-40	3.35	1.88	3.90%	

TABLE 3. Some IR Spectra Characteristics of CL-PVA with Various Degrees of Crosslinking

Type of gel	Characteristic frequency ranges of associated HO- groups, $\text{cm}^{-1}$	Absorbance, $\lambda_{\text{max}} = 3420 \text{ cm}^{-1}$	Observations
CL-PVA-X-5	2980-3660	0.422	A larger band in the case of CL-PVA-X-5 is due to the higher percentage of associated HO- groups.  The characteristic frequency range of HO-vibration is reduced more in the case of CL-PVA-X-40, in which the hydrogen association is hindered.
CL-PVA-X-20	3090-3600	0.468	
CL-PVA-X-40	3100-3600	0.460	

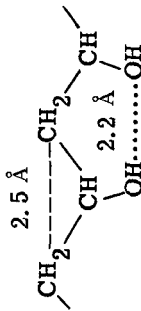
is much larger in the case of CL-PVA-X-5 compared with CL-PVA-X-20 and CL-PVA-X-40 (Table 3). The largest frequency field, obtained for CL-PVA-X-5, denotes the highest number of associated HO- groups. That generates maximum contraction of this gel with a minimum degree of reticulation. The IR spectra are practically identical for all the remaining samples.

X-ray data are presented in Table 4. The diagrams obtained, besides indicating an amorphous structure characteristic of polymer compounds, has three peaks assigned to an ordered crystalline structure. Peaks with maximum relative intensities ( $I/I_m$ ) were observed at the  $\theta_2$  angle (around  $9.8^\circ$ ). These maximum intensity peaks are assigned to the interchain hydrogen association, which permitted evaluation of the degree of organization of the structure. Our conclusion was that PVA-X-5 presents the most organized structure due to its high degree of interchain hydrogen association (PVA-X-5 exhibits the minimum width in all directions).

Experiments carried out with a 8-M urea solution supported our point of view. It is well known that 8 M urea solutions are able to break hydrogen bonds. In our case, for all CL-PVA gels the swelling capacities are higher in 8 M urea solution than in water (because the gels are not as contracted by hydrogen associations). The difference

TABLE 4. X-Ray Diffraction Data for Different Cl-PVA Gels

X-ray data	Sample				Assigned to <sup>a</sup>
	PVA	CL-PVA-X-5	CL-PVA-X-20	CL-PVA-X-40	
$\theta_1$	5.607°	5.648°	5.581°	5.466°	Interchain glycerine bridges (calculated size, 8.34 Å)
$d_1$	7.875 Å	7.818 Å	7.912 Å	8.078 Å	
$I/I_m$	0.085	0.111	0.117	0.088	
$\Delta\theta_1$	2.40°	1.65° <sup>b</sup>	2.40°	2.85°	
$\theta_2$	9.800°	9.837°	9.837°	9.707°	Interchain hydrogen association (calculated size, 5.5 Å)
$d_2$	4.521 Å	4.504 Å	4.504 Å	4.564 Å	
$I/I_m$	1 <sup>c</sup>	1 <sup>c</sup>	1 <sup>c</sup>	1 <sup>c</sup>	
$\Delta\theta_2$	1.725°	1.35° <sup>b</sup>	1.50°	1.72°	
$\theta_3$	20.504°	20.463°	20.620°	20.454°	Hydrogen bonds between vicinal HO-groups:
$d_3$	2.197 Å	2.201 Å	2.185 Å	2.202 Å	
$I/I_m$	0.151	0.115	0.136	0.153	
$\Delta\theta_3$	2.55°	1.57° <sup>b</sup>	1.875°	2.10°	



<sup>a</sup>Deviations from standard distances have been accounted for by local distortions induced by hydrogen bonds and/or the complex conformations of PVA compounds.

<sup>b</sup>The minimum values for  $\Delta\theta_2$  in all directions of PVA-X-5 denote the highest regular organized structure.

<sup>c</sup>Maximum intensity of these peaks denotes the large frequency of this distance ( $d_2$ ) in the assembly of the organized structure.

TABLE 5. Swelling Capacity of Cl-PVA Gels in Water and 8 M Urea Solutions

Type of gel	mL gel bed/g		$\Delta V$	Observation
	H <sub>2</sub> O	8 M urea		
CL-PVA-X-5	3.33	3.80	14%	Higher hydrogen associations in the case of Cl-PVA-X-5
CL-PVA-X-20	4.45	4.85	9%	

in swelling capacity is higher in the case of CL-PVA-X-5 than in the case of CL-PVA-X-20 (Table 5). The conclusion was that PVA-X-5 exhibits much more hydrogen association than PVA-X-20.

From all the above data, evidence was offered to support our supposition concerning the main role of hydrogen bonds in the network organization, schematically presented in Scheme I.

It is possible these hydrogen associations can explain the excellent mechanical qualities and the high osmotic stability of these gels [14] (Table 6).

Beaded CL-PVA was used as a support for introducing ion-exchange groups [7, 8] or other specific ligands in order to obtain stationary phases for ion-exchange chromatography and affinity chromatography. The methods of ion-exchange synthesis are presented in Schemes II and III.

Two types of CL-PVA gels were obtained at bead size distributions in the range 0.2-0.4 and 0.4-0.6 mm, respectively.

The capacity of exchangers can be controlled by the reagent/CL-PVA ratio (Table 7). In all cases the introduction of polar ion-exchange groups increases the swelling properties.

The main utilization of these ion exchangers is to separate biological compounds. For this reason, the exchange capacities were chosen (by synthesis) in such a range as to permit the preservation of biological activity of the samples. A high exchange capacity is known to induce denaturation of labile biological compounds by steric impediments that can only be avoided by using spacer arms. On the other hand, in the case of a very inadequate exchange capacity, denaturation may be due to drastic elution conditions—pH or salt concentration modifications.

The ionic PVA exchangers obtained by our procedure exhibit high osmotic stability (Table 6), ranging from 80 to 95%, with good uniformity of particles. The stability of anionic exchangers is higher than that of cationic exchangers, and this may be due to both the hydrophilic and hydrophobic character of the functional groups. This high osmotic resistance is, to a certain extent, due to the reduced variation of bed volume when the pH and ionic concentration of the medium are changed. These two effects are probably related to high interchain associations.

TABLE 6. Osmotic Stability of Ion-Exchange Resin Based on CL-PVA (macrocylic device)

Ion-exchange resin	Final values		Osmotic stability, <sup>c</sup> %
	Effective size, <sup>a</sup> mm	Uniformity coefficient <sup>b</sup>	
CL-PVA-X-2.5	0.52	1.57	80
CL-PVA-X-30	0.58	1.61	83
CM-PVA-X-30	0.49	1.52	80
DEAE-PVA-X-30	0.60	1.63	94
TEAE-PVA-X-30	0.60	1.69	96
ECTEOA-PVA-X-30	0.62	1.69	95

<sup>a</sup>The size of a screen opening that will retain 90% of the sample (initial size of all resins, 0.66 mm).

<sup>b</sup>Ratio of the 40% value of the particle oversize distribution to its 90% value (effective size).

<sup>c</sup>Ratio of the number of whole particles after the osmotic test to the number of whole particles before the osmotic test, calculated in percentages.

Some possibilities for the use of CL-PVA derivatives as stationary phases in HPLC were considered. A chelating exchanger based on beaded CL-PVA was obtained (Scheme IV). Our product exhibits the same functional group as some commercial exchangers (Chellex 100 produced by BioRad and Chelating Sepharose 6 B produced by Pharmacia Uppsala), but obtained by other procedures.

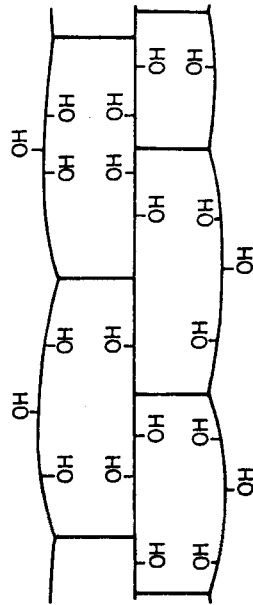
Another product, Blue-CL-PVA (Fig. 9), was obtained by CL-PVA reaction with Cibachron Blue, a reactive dye. The product exhibits the same functional group as the commercial products Blue Sepharose and AffiGelBlue, and can be used in the specific adsorption or affinity chromatography of more than 50 enzymes and many protein purifications.

CL-PVA exchangers can also be used as acidic or basic catalysts. For instance, we used P-PVA as an acidic catalyst for some ester syntheses. For the synthesis of some esters like menthyl and bornyl acetates, the use of solid cationic exchangers avoids the formation of double bonds (generating by-products). The yield of ester preparation was over 80%, and a product of high purity and good olfactory qualities (necessary in cosmetics) was obtained.



Type of gel	Schematic diagram of hypothetical structure of CL-PVA with different crosslinking degree	Gel bed, mL/g	Observation
CL-PVA-X-5		3.33	Reduced crosslinking degree; most contracted network due to the high number of interchain hydrogen associations.
CL-PVA-X-10		3.90	Tight network; more interchain glyceric bridges; reduced number of hydrogen associations as in the case of CL-PVA-X-5

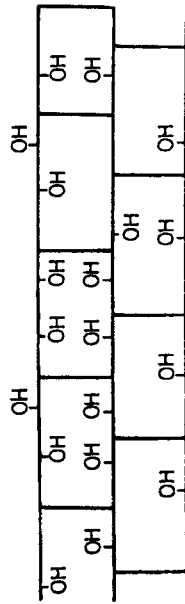
CL-PVA-X-20



4.45

High crosslinking degree; much more interchain glyceric bridges; hydrogen association is avoided; the most expanded network due to hydration of the HO-group.

CL-PVA-X-30

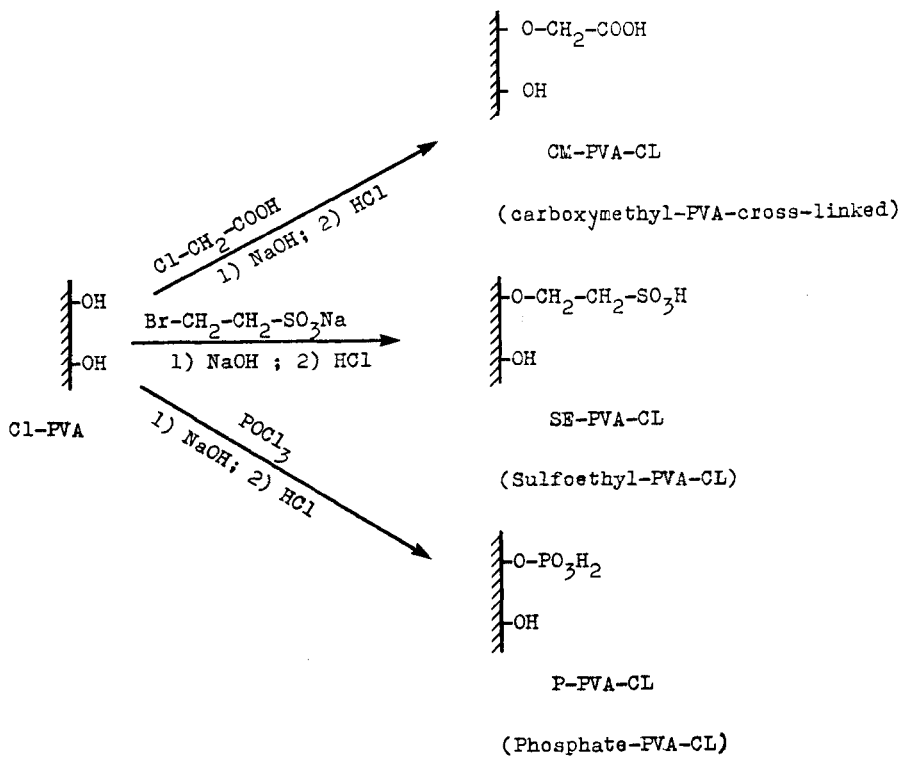


3.90

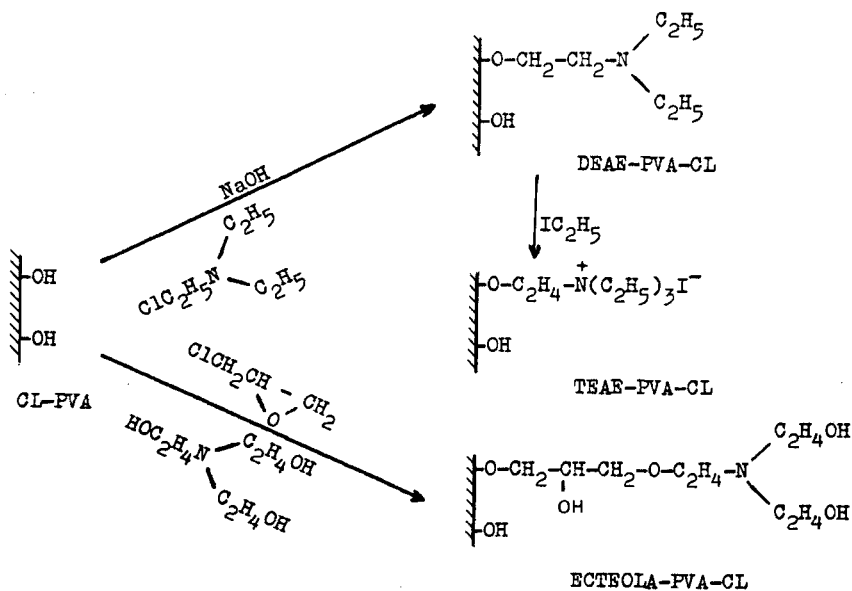
Advanced crosslinking degree; height of network due to the high number of interchain glyceric bridges.

— = PVA chains; | = interchain glyceric bridges; | | = interchain hydrogen bonds.

SCHEME I. Hypothetical structure of CL-PVA with various crosslinking degrees.



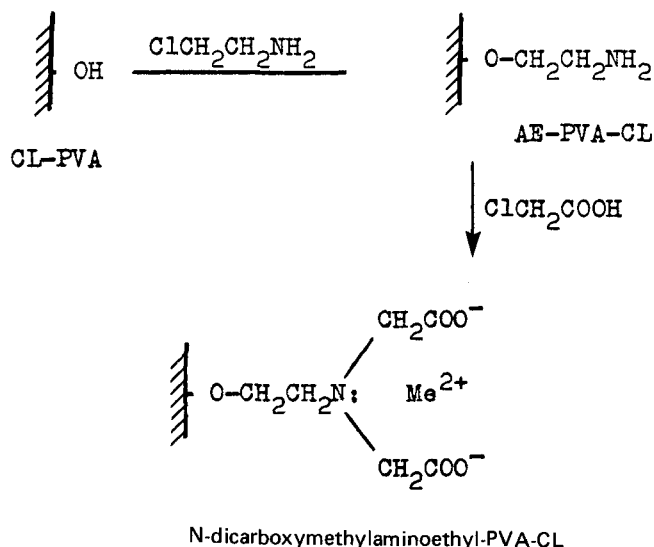
**SCHEME II.** Synthesis of cationic-exchange resin based on CL-PVA.



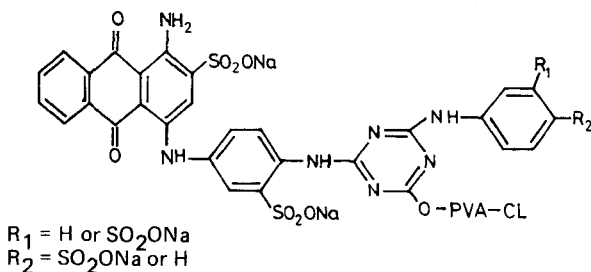
**SCHEME III.** Synthesis of anionic-exchange resin based on CL-PVA.  
ECTEOLA = epichlorohydrin-triethanolamine.

TABLE 7. Some Physicochemical Properties of Ion-Exchange Resins Based on CL-PVA

PVA resin	Exchange capacity, $10^{-1}$		Swelling capacity, mL wet resin/g dry resin	Water regain, g H <sub>2</sub> O/g dry resin
	meq/mL	meq/g dry resin		
CL-PVA-X-20	0	0	4.45	2.28
CM-PVA-X-20	0.60	2.9	4.49	2.29
	0.87	4.8	4.83	2.85
SE-PVA-X-20	0.17	0.8	4.70	2.70
	0.26	1.4	5.55	2.85
P-PVA-X-20	0.27	1.2	4.55	3.23
	0.44	4.3	9.75	4.50
DEAE-PVA-X-20	0.25	1.2	4.80	2.80
	0.50	2.4	5.80	3.10
TEAE-PVA-X-20	0.40	2.5	6.20	3.22
	0.85	6.0	7.10	3.70
ECTEOLA-PVA-X-20	0.40	2.4	6.15	3.15
	0.80	5.5	6.90	3.54



**SCHEME IV.** Synthesis of chelating ion-exchange resin including iminodiacetic acid function based CL-PVA.



**FIG. 9.** Structure of blue-PVA-CL.

### THE USE OF BEADED CL-PVA DERIVATIVES AS SUPPORTS FOR ENZYME IMMOBILIZATION AND FOR AFFINITY CHROMATOGRAPHY

Enzyme catalysis is very attractive for both technologists and scientists. Solid-phase enzyme catalysis using immobilized enzymes in different ways and on various supports, is now used in modern plants. The main advantages of immobilized enzymes are:

The possibility of recuperating the enzyme and reusing it several times.

The possibility of obtaining products not contaminated with the enzyme (important for drug chemistry to avoid immunological accidents).

Increasing the stability of an enzyme by the modification of pH, temperature, and the action of some inhibitors.

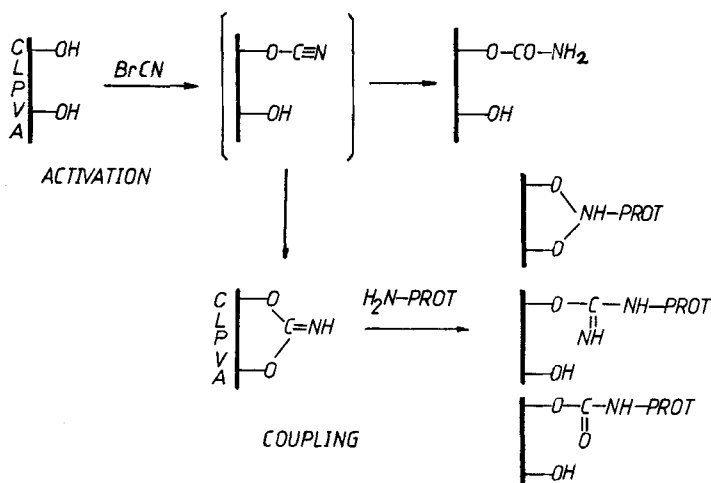
Increasing the stability over time.

Continuous transfer of equilibrium in favor of the desired products (by using continuous flow systems, they are released from the catalyst surface).

There are many supports for enzyme immobilization. A number of polyhydroxyl compounds are used as supports, e.g., dextran (Sephadex), cellulose, and Sepharose gels [15-17].

By taking advantage of the bead form and hydroxyl group reactivity, we tried using CL-PVA as a support for enzyme immobilization. Unlike other methods (physical adsorption, crosslinking, etc.), we chose covalent binding because, although the retained activity is not very high, the stability is greater than with other immobilization methods.

Thus, lipase, an enzyme with important applications such as catalyzing the hydrolysis of glycerol with fatty acid esters, was immobilized [18] on CL-PVA activated with cyanogen bromide (Scheme V) [19]. The immobilized enzyme exhibits a much higher stability toward pH, temperature, and some cationic inhibitors than the free enzyme (Fig. 10).



**SCHEME V.** Enzyme immobilization on CL-PVA by cyanogen procedure.

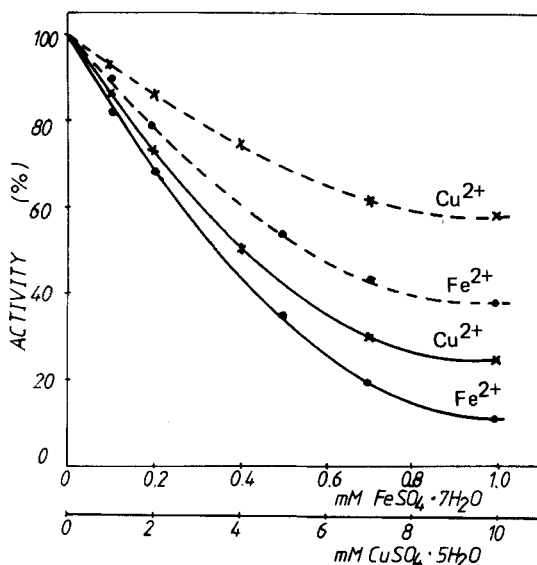


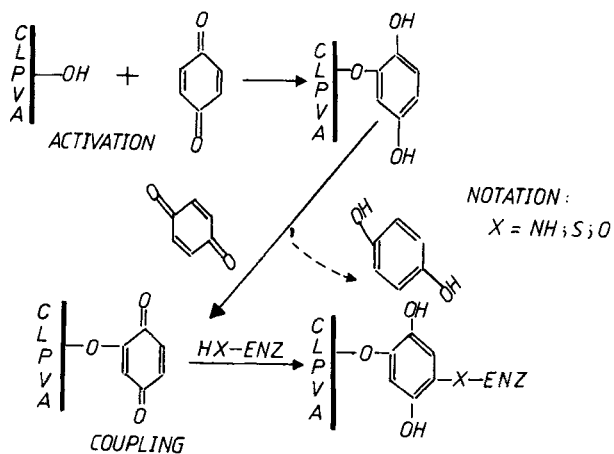
FIG. 10. The influence of  $\text{FeSO}_4$  and  $\text{CuSO}_4$  on the enzymatic activity of free (—) and immobilized (---) lipase.

$\alpha$ -Amylase, the enzyme which hydrolyses starch and its derivatives, was immobilized [20] by p-benzoquinone activation of CL-PVA (by the Porath procedure [15]) (Scheme VI). A batch microreactor with simple stirring was used for continuous starch hydrolysis. We established high conversions in the first minutes of reaction (Fig. 11). The stability over time was maintained for several months. The same product was used in the "on-column catalysis" system with a continuous flow rate of the substrate.

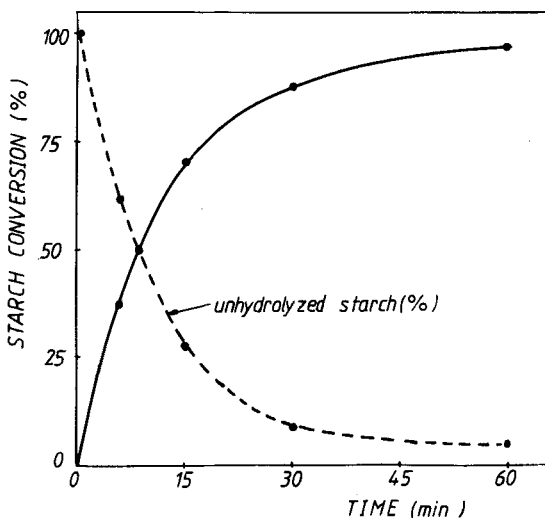
The carboxymethylated CL-PVA was used for protein immobilization using the carbodiimide [21] procedure (Scheme VII).

For instance, pepsin was immobilized on CM-PVA by this procedure [22]. Pepsin is an enzyme with a high specific dependence on pH (the optimum activity ranges between 1.8 and 2.2 pH units, characteristic of stomach media). By immobilization, the enzyme exhibits an optimum pH around 4.0 (Fig. 12), probably due to some structural modification of the enzyme or to some microenvironmental modifications at the surface of the support.

CL-PVA beads were also used in affinity chromatography. Affinity chromatography is a most attractive separation procedure. It is based on the steric and functional complementary relationship between the compound to be separated from the sample and the specific ligand that is immobilized on the support.

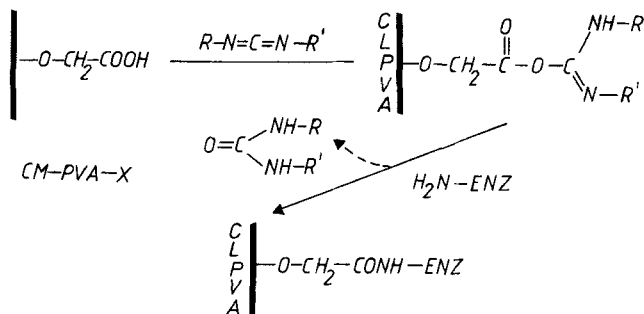


**SCHEME VI.** Enzyme immobilization on CL-PVA by p-benzoquinone procedure.

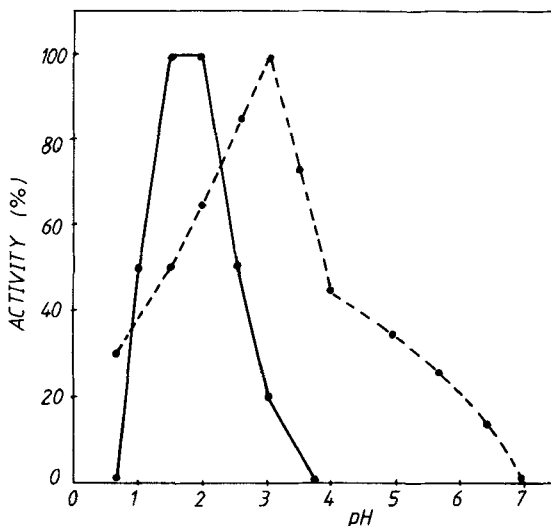


**FIG. 11.** Time course of starch hydrolysis in a batch reactor with  $\alpha$ -amylase immobilized on CL-PVA.





**SCHEME VII.** Enzyme immobilization on CL-PVA gel using carbodiimide procedure.



**FIG. 12.** The influence of pH on the proteolytic activity of free (—) and immobilized (--) pepsin on CM-PVA-CL.

We used immobilized  $\alpha$ -chymotrypsin (by cyanogen bromide) on CL-PVA as a stationary phase for a single-step separation of some specific protein inhibitors of this enzyme (Fig. 13) [23].

If we compare CL-PVA with other polyhydroxy-containing stationary phases with polysaccharide structures, the advantage of CL-PVA is that it cannot be used as a carbon source for microorganisms and it is not infected. This is probably one explanation for the increased stability over time of immobilized enzymes on CL-PVA. The product is not toxic and some clinical applications are expected.

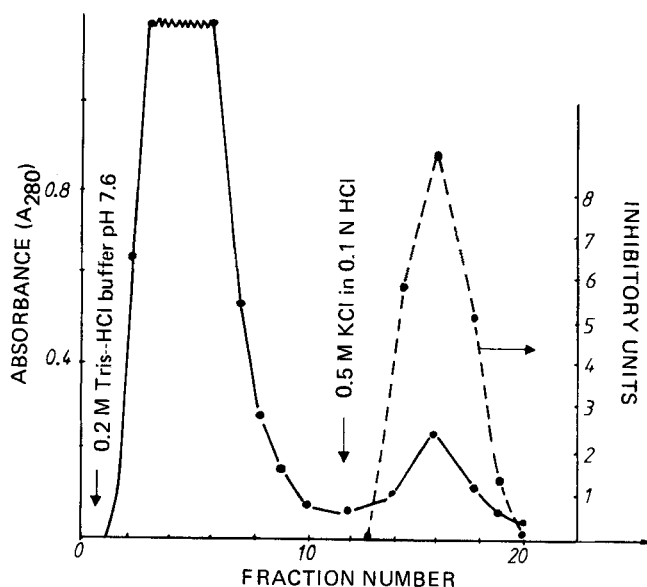


FIG. 13. Affinity chromatography separation of  $\alpha$ -chymotrypsin inhibitors on  $\alpha$ -chymotrypsin immobilized on a CL-PVA column.

The efficiency of chromatographic separations on CL-PVA beads is probably due to the alternating polar HO- groups and nonpolar methylenic  $-\text{CH}_2-$  groups. Therefore, artifacts due to nondesired hydrogen bonds between sample and support are partially avoided (much more than in the case of cellulose or Sepharose supports).

Further developments concerning the use of CL-PVA derivatives in some other fields of enzymatic processes will be dealt with in future papers.

#### REFERENCES

- [1] G. Manecke and H. G. Vogt, *Biochimie*, **62**, 601 (1980).
- [2] I. Matsumoto, Y. Ito, and N. Seno, *J. Chromatogr.*, **239**, 747 (1982).
- [3] I. Sakurada, *Gohsei Seni Kenkyu*, **1**, 192 (1948); *Chem. Abstr.*, **44**, 8161 (1950).
- [4] M. Dimonie, C. Cincu, C. Oprescu, and G. Hubca, *J. Polym. Sci., Polym. Symp.*, **64**, 245 (1978).
- [5] M. Dimonie, C. Oprescu, G. Hubca, M. Corobea, and C. Cincu, *Romanian Patent* 68,949 (1978).
- [6] G. Hubca, C. Oprescu, M. Iosif, M. A. Mateescu, and M. Dimonie,

- "Suspension Methanolysis of Polyvinyl Acetate," in Abstracts, IUPAC MACRO '83, Polymer Chemistry, (Section I), Bucharest, Romania, 1983, p. 146.
- [7] M. A. Mateescu, H. D. Schell, M. Dimonie, T. Bentia, C. Dimitriu, and O. Maior, Rev. Roum. Chim., **26**, 117 (1981).
- [8] H. D. Schell, M. A. Mateescu, M. Dimonie, C. Opreescu, and T. Bentia, Roumanian Patent 74,486 (1980).
- [9] M. A. Mateescu, H. D. Schell, S. Todireanu, M. Dimonie, O. Maior, and T. Bentia, "Some Peculiar Properties of CL-PVA Related to the Reticulation Degree," in Abstracts, IUPAC MACRO '83, Structure and Properties (Section IV), Bucharest, Romania, 1983, p. 461.
- [10] M. A. Mateescu, H. D. Schell, M. Dimonie, S. Todireanu, O. Maior, and S. Moldoveanu, Polym. Bull., In Press.
- [11] T. Kremmer and L. Boross, Gel Chromatography. Theory, Methodology, Applications, Akademiai Kiado, Budapest, 1979.
- [12] H. D. Schell and V. Ghetie, Stud. Cercet. Biochim., **11**, 69 (1968).
- [13] M. Serban, H. D. Schell, and M. A. Mateescu, Rev. Roum. Biochim., **12**, 187 (1975).
- [14] H. D. Schell, M. A. Mateescu, M. Dimonie, O. Maior, V. Florea, V. Craciun, and T. Bentia, "Beaded Porous CL-PVA Ionic Exchangers," in Abstracts of 2nd National Congress of Chemistry, Vol. 2, Bucharest, 1981, p. 677.
- [15] J. Porath and R. Axén, in Methods in Enzymology, Vol. 44 (S. P. Colowick and N. O. Kaplan, eds.), Academic, New York, 1976, p. 19.
- [16] H. H. Weetall, in Immobilized Enzymes for Industrial Reactors (R. A. Messing, ed.), Academic, New York, 1975.
- [17] I. Chibata, Immobilized Enzymes—Research and Development, Kodansha, Tokyo, 1978.
- [18] O. Gozia, H. D. Schell, V. Lazar, and O. Moldoveanu, Stud. Cercet. Biochim., **26**, 40 (1983).
- [19] R. Axén, J. Porath, and S. Ernback, Nature, **214**, 1302 (1967).
- [20] H. D. Schell and T. Bene, Stud. Cercet. Biochim., **26**, 273 (1983).
- [21] R. A. Messing, Enzymologia, **38**, 370 (1970).
- [22] H. D. Schell, D. Banateanu, and T. Bentia, Rev. Roum. Biochim., **12**, 187 (1980).
- [23] D. Banateanu, H. D. Schell, T. Bentia, and R. Scripca-Cristoff, Stud. Cercet. Biochim., **26**, 92 (1983).